

BR 150 - 3000



Hot water storage tank

BR 150 - 3000

Application

This hot water storage tank is equipped with a smooth pipe heat exchanger and can be used as an auxiliary storage tank for various heating boilers, such as oil, gas, solid fuel and similar.

Corrosion protection for parts with drinking water contact

Enamelled as per DIN 4753. A magnesium anode offers additional corrosion protection.

External corrosion protection

Up to 500 l protective enamelled layers and foam encased
800 to 2,000 l powder-coated

Heat insulation

Type 150-600: 50 mm PU rigid foam insulation with soft sleeve

Type 800-1000: 95 mm PU rigid foam half-shell with soft sleeve

Type 1500-3000: 110 mm half-shell made of EPS with ABS sleeve

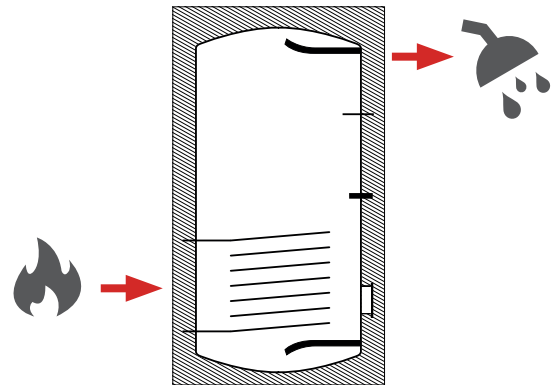

Model overview BR 150 - 3000

Type	Article no.	Volume	Height with insulation	Tilt height	Installation diameter	Weight (empty)	Surface HE bottom	Output figure	Efficiency class
Unit	[-]	[l]	[mm]	[mm]	[mm]	[kg]	[m ²]	[-]	[-]
BR 150	STD0150BR	151	950	1135	610	74	1	2,2	B
BR 200	STD0200BR	201	1215	1370	610	91	1,3	4,0	C
BR 300	STD0300BR	326	1570	1710	660	123	1,5	6	C
BR 400	STD0400BR	415	1500	1690	760	147	1,8	10,4	C
BR 500	STD0500BR	496	1800	1960	760	164	2,3	14	C
BR 600	STD0600BR	559	2000	2150	760	190	2,3	16	C
BR 800	STD0800BR	805	1990	2020	790	270	3,6	22	C
BR 1000	STD1000BR	910	2190	2220	790	295	3,6	34	C
BR 1500	STD1500BR	1450	2240	2240	1000	420	3,3	40	C
BR 2000	STD2000BR	1912	2420	2430	1100	510	4,4	46	C
BR 2500	STD2500BR	2435	2590	2650	1200	-	5,3	-	C
BR 3000	STD3000BR	2900	2800	2810	1250	-	5,3	-	C

Hot water storage tank

Technical specifications BR 150 - 600

Type	Unit	BR 150	BR 200	BR 300	BR 400	BR 500	BR 600
Article no.	[-]	STD0150BR STD0150BR.H	STD0200BR STD0200BR.H	STD0300BR STD0300BR.H	STD0400BR STD0400BR.H	STD0500BR STD0500BR.H	STD0600BR STD0600BR.H
Volume	[l]	151	201	326	415	496	559
Drinking water content	[l]	145	192,8	317	404	481	544
Content HE bottom	[l]	6	8,2	9	11	15	15
Height with insulation	[mm]	950	1215	1570	1500	1800	2000
Diameter with insulation	[mm]	610	610	660	760	760	760
Diameter without insulation	[mm]	-	-	-	-	-	-
Tilt height	[mm]	1135	1370	1710	1690	1960	2150
Installation diameter	[mm]	610	610	660	760	760	760
Weight (empty)	[kg]	74	91	123	147	164	190
Max. operating pressure heating side	[bar]	10	10	10	10	10	10
Test pressure heating side	[bar]	15	15	15	15	15	15
Max. operating pressure hot drinking water side	[bar]	10	10	10	10	10	10
Test pressure hot drinking water side	[bar]	15	15	15	15	15	15
Max. operating temperature heating side	[°C]	95	95	95	95	95	95
Max. operating temperature hot drinking water side	[°C]	95	95	95	95	95	95
Surface HE bottom	[m²]	1	1,3	1,5	1,8	2,3	2,3
Insulation thickness	[mm]	50	50	50	50	50	50
Max. installation length EHP	[mm]	450	500	500	650	650	650
Max. output EHP	[kW]	1,5	2	2,5	4	4	6
Output figure	[-]	2,2	4,0	6	10,4	14	16
On-demand heat overhead	[kWh/d]	1,21	1,60	1,80	2,40	2,60	2,60
Holding losses	[W]	50	68	75	101	107	110
Efficiency class	[-]	B	C	C	C	C	C
Pressure loss heating side	[mbar]	60	74	90	102	167	192
Flow rate heating side	[m³/h]	1,8	2,3	2,7	3,1	3,8	4,3
Insulation material	[-]	PU rigid foam ($\lambda=0.024$ W/mK)					
Corrosion protection	[-]	Enamelled as per DIN 4753, magnesium anode					

Output data BR 150 - 600

	Continuous output at supply temperature ¹						Values as per DIN4708 (data relative to output figure) ²						Draw-off performance in 60 min ³
	50 °C		60 °C		70 °C		NL	Max. draw-off performance in 10 min		Draw-off performance after 30 min		Supply temp. 70 °C	
	[kW]	[l/h]	[kW]	[l/h]	[kW]	[l/h]		[l]	[l/min]	[l]	[l/min]	[l]	
HE bottom	150	4,2	103	12,0	295	21,0	516	2,2	204	20,4	81	18,5	690
	200	5	123	15,0	369	26,0	639	4	290	29,0	149	27,0	900
	300	6,3	154	18,0	442	31,5	774	6,0	325	32,5	220	27,0	1109
	400	7,1	175	20,4	501	35,8	877	10,4	423	42,4	381	33,7	1423
	500	8,8	216	25,2	619	45,7	1083	14,0	478	47,8	474	37,5	1678
	600	10,1	248	28,8	708	45,7	1238	16	536	53,6	580	41,5	1881

1 - Heating from CW 10 °C to WW 45 °C

2 - Heating from CW 10 °C to WW 45 °C; supply 70 °C; storage tank temperature CW + 50 K

3 - Computed data at maximum output; CW 10 °C to WW 45 °C; storage tank temperature 60 °C

Connections and dimensions BR 150 - 600

Connections		Unit	BR 150	BR 200	BR 300	BR 400	BR 500	BR 600
FO	Top sensor	[mm]	950 ½" IT	1215 ½" IT	1570 ½" IT	1500 ½" IT	1800 ½" IT	2000 ½" IT
WW	Hot water	[mm]	950 1¼" IT	1215 1¼" IT	1570 1¼" IT	1500 1¼" IT	1800 1¼" IT	2000 1¼" IT
AN	Anode	[mm]	950 1¼" IT	1215 1¼" IT	1570 1¼" IT	1500 1¼" IT	1800 1¼" IT	2000 1¼" IT
Z	Circulation	[mm]	740 ½" IT	950 ½" IT	1200 ½" IT	1150 ½" IT	1400 ½" IT	1550 ½" IT
HZV	Heating supply	[mm]	640 1" IT	780 1" IT	840 1" IT	855 1" IT	1020 1" IT	1020 1" IT
F/TH	Circulation	[mm]	740 ½" IT	1000 ½" IT	1350 ½" IT	1250 ½" IT	1550 ½" IT	1750 ½" IT
FHZ	Heating sensor	[mm]	-	-	570 ½" IT	590 ½" IT	600 ½" IT	600 ½" IT
HZR	Heating return	[mm]	240 1" IT	240 1" IT	240 1" IT	255 1" IT	255 1" IT	255 1" IT
KW	Cold water	[mm]	130 1¼" IT	130 1¼" IT	140 1¼" IT	155 1¼" IT	155 1¼" IT	155 1" IT
EHP	Electric heating cartridge	[mm]	-	840 1½" IT	910 1½" IT	920 1½" IT	1090 1½" IT	-
FLO	Flange top	[mm]	-	-	-	-	-	1080 Ø 180/120
FLU	Flange bottom	[mm]	285 Ø 180/120	285 Ø 180/120	295 Ø 180/120	310 Ø 180/120	310 Ø 180/120	310 Ø 180/120
ANS	Anode side	[mm]	-	-	-	-	-	625 1¼" IT

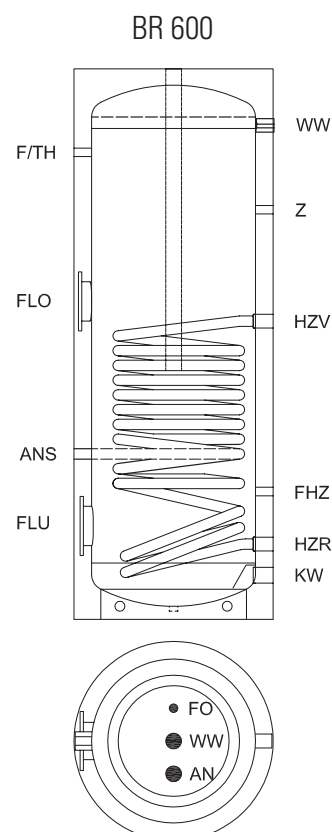
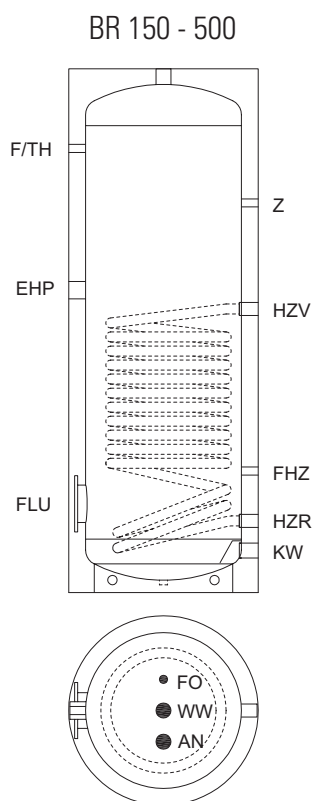

Hot water storage tank

Technical specifications BR 800 - 3000

Type	Unit	BR 800	BR 1000	BR 1500	BR 2000	BR 2500	BR 3000
Article no.	[-]	STD0800BR	STD1000BR	STD1500BR	STD2000BR	STD2500BR	STD3000BR
Volume	[l]	805	910	1450	1912	2435	2900
Drinking water content	[l]	774	879	1422	1874	2390	2855
Content HE bottom	[l]	31	31	28	38	45	45
Height with insulation	[mm]	1990	2190	2240	2420	2590	2800
Diameter with insulation	[mm]	990	990	1250	1350	1450	1500
Diameter without insulation	[mm]	790	790	1000	1100	1200	1250
Tilt height	[mm]	2020	2220	2240	2430	2650	2810
Installation diameter	[mm]	790	790	1000	1100	1200	1250
Weight (empty)	[kg]	270	295	420	510	-	-
Max. operating pressure heating side	[bar]	10	10	6	6	6	6
Test pressure heating side	[bar]	15	15	12	12	12	12
Max. operating pressure hot drinking water side	[bar]	10	10	10	10	10	10
Test pressure hot drinking water side	[bar]	15	15	15	15	15	15
Max. operating temperature heating side	[°C]	95	95	95	95	95	95
Max. operating temperature hot drinking water side	[°C]	95	95	95	95	95	95
Surface HE bottom	[m²]	3,6	3,6	3,3	4,4	5,3	5,3
Insulation thickness	[mm]	95	95	110	110	110	110
Max. installation length EHP	[mm]	800	800	830	930	1030	1080
Max. output EHP	[kW]	7,5	7,5	24	24	45	45
Output figure	[-]	22	34	40	46	-	-
On-demand heat overhead	[kWh/d]	3,10	3,40	3,90	4,40	-	-
Holding losses	[W]	129	142	163	183	-	-
Efficiency class	[-]	C	C	C	C	C	C
Pressure loss heating side	[mbar]	180	180	234	246	-	-
Flow rate heating side	[m³/h]	6,5	6,5	7	7	-	-
Insulation material	[-]	PU rigid foam shell			EPS		
Corrosion protection	[-]	Enamelled as per DIN 4753, magnesium anode					

Output data BR 800 - 2000

	Continuous output at supply temperature ¹						Values as per DIN4708 (data relative to output figure) ²						Draw-off performance in 60 min ³
	50 °C		60 °C		70 °C		NL	Max. draw-off performance in 10 min		Draw-off performance after 30 min		Supply temp. 70 °C	
	[kW]	[l/h]	[kW]	[l/h]	[kW]	[l/h]		[l]	[l/min]	[l]	[l/min]	[l]	
HE bottom	800	12,2	299	34,8	855	60,9	1496	22,0	645	64,5	792	49,1	2818
	1000	15,1	371	43,2	1061	75,6	1857	34,0	839	83,9	1214	62,6	2953
	1500	16,4	402	46,8	1150	81,9	2012	40	929	92,9	1423	68,8	3871
	2000	17,2	423	49,2	1209	86,1	2115	46	1021	102,1	1631	75,2	4520

1 - Heating from CW 10 °C to WW 45 °C

2 - Heating from CW 10 °C to WW 45 °C; supply 70 °C; storage tank temperature CW + 50 K

3 - Computed data at maximum output; CW 10 °C to WW 45 °C; storage tank temperature 60 °C

Connections and dimensions BR 800 - 3000

Connections		Unit	BR 800	BR 1000	BR 1500	BR 2000	BR 2500	BR 3000
FO	Top sensor	[mm]	1940 ½" IT	2140 ½" IT	-	-	-	-
WW	Hot water	[mm]	1765 2" IT	1965 2" IT	1890 2" IT	2060 2" IT	2200 2" IT	2390 2" IT
AN	Anode	[mm]	1940 1¼" IT	2140 1¼" IT	2170 1¼" IT	2350 1¼" IT	2540 1¼" IT	2730 1¼" IT
AN	Anode	[mm]	-	-	2170 1¼" IT	2350 1¼" IT	2540 1¼" IT	2730 1¼" IT
Z	Circulation	[mm]	1400 1" IT	1600 1" IT	1600 1" IT	1750 1" IT	1900 1" IT	1900 1" IT
HZV	Heating supply	[mm]	1195 1" ¼ IT	1195 1" ¼ IT	1050 1¼" IT	1170 1¼" IT	1400 1¼" IT	1400 1¼" IT
F/TH	Circulation	[mm]	1650 ½" IT	1850 ½" IT	1790 ½" IT	1960 ½" IT	2080 ½" IT	2270 ½" IT
FHZ	Heating sensor	[mm]	660 ½" IT	660 ½" IT	620 ½" IT	640 ½" IT	885 ½" IT	885 ½" IT
HZR	Heating return	[mm]	275 1" ¼ IT	275 1" ¼ IT	390 1¼" IT	400 1¼" IT	450 1¼" IT	450 1¼" IT
KW	Cold water	[mm]	175 2" IT	175 2" IT	280 2" IT	290 2" IT	340 2" IT	340 2" IT
FLO	Flange top	[mm]	1400 Ø 180/120	1400 Ø 180/120	1230 Ø 180	1400 Ø 180/120	1500 Ø 180/120	1500 Ø 180/120
FLU	Flange bottom	[mm]	350 Ø 290/220	350 Ø 290/220	500 Ø 290	520 Ø 290/220	570 Ø 290/220	570 Ø 290/220
ANS	Anode side	[mm]	690 1" ¼ IT	690 1" ¼ IT	830 1¼" IT	840 1¼" IT	885 1¼" IT	885 1¼" IT
ENT	Ventilation	[mm]	1940 1" ¼ IT	2140 1" ¼ IT	2170 1¼" IT	2350 1¼" IT	2540 1¼" IT	2730 1¼" IT

